

**OPERATING INSTRUCTIONS  
EB 2700**

for

**Universal Bridge  
TF 2700**

Copyright © 1962

**MARCONI INSTRUMENTS LIMITED  
ST. ALBANS HERTFORDSHIRE ENGLAND**

C. P. 1k  
3/66/K

EB 2700  
1g - 3/66

## CONTENTS

Section	Page
1	GENERAL INFORMATION ... .. 3
1.1	Features ... .. 3
1.2	Data Summary ... .. 4
1.3	Optional Accessories ... .. 6
2	OPERATION ... .. 7
2.1	General ... .. 7
2.1.1	Balancing the Bridge ... .. 7
2.1.2	Reading the Result ... .. 8
2.2	Battery Check ... .. 9
2.3	Connections ... .. 9
	Fig. 2.3 Controls and Operating Facilities ... .. 10
2.4	Capacitance Measurements ... .. 12
2.4.1	—using the Internal 1 kc/s Source ... .. 12
2.4.2	—using an External A. F. Source ... .. 13
2.4.3	Electrolytic Capacitors and use of Polarizing Bias ... .. 13
2.4.4	Capacitance to True Earth ... .. 14
2.5	Inductance Measurements ... .. 15
2.5.1	—using the Internal 1 kc/s Source ... .. 15
2.5.2	—using an External A. F. Source ... .. 16
2.5.3	Incremental Inductance and use of Polarizing Bias ... .. 16
2.6	Resistance Measurements ... .. 20
2.6.1	—using the Internal 1 kc/s Source ... .. 21
2.6.2	—using an External A. F. Source ... .. 21
2.6.3	—using the Internal Battery ... .. 22
2.6.4	—using an External D. C. Source ... .. 23
2.7	Connection of External A. C. Source ... .. 25
2.8	Loss Balance — Q or D ... .. 27
3	CIRCUIT SUMMARY ... .. 28
3.1	Bridge Circuits ... .. 28
3.2	Bridge Energizing Sources ... .. 29
3.3	Detector ... .. 29
4	MAINTENANCE NOTES ... .. 31
4.1	Replacement of the Battery ... .. 31
4.2	Replacement of Circuit Components ... .. 31
4.2.1	Access to Interior ... .. 31
4.2.2	Adjustment of Detector Sensitivity ... .. 32
4.2.3	Oscillator Frequency ... .. 32
4.2.4	Range Resistor R13 ... .. 32
	CIRCUIT DIAGRAM ... .. inside back cover

# I GENERAL INFORMATION

## I.1 FEATURES

The TF 2700 Universal Bridge is a compact, self contained instrument that brings new versatility to the rapid determination of a wide range of impedance values. Facilities are provided for the application of external a.c. and d.c. supplies for use in a variety of specialized measurement procedures.

The internal energizing sources for the bridge are a 1 kc/s oscillator for a.c. measurements of capacitance, inductance and resistance; and the 9 V power supply battery for d.c. resistance measurements. The detector has been designed to have a usable response from 20 c/s to 20 kc/s. This allows an external source to be used to energize the bridge for measurements over a more representative range of frequencies. D.C. voltages higher than that of the battery may also be applied externally for improved discrimination with resistance measurements.

Another facility enables a d.c. bias to be applied to the component under test. Up to 500 V may be used for polarizing electrolytic capacitors or for investigating the properties of non-linear resistors. Alternatively, up to 40 mA may be passed through iron cored inductors by suitable external connections or up to 200 mA when using the D.C. Choke Adaptor, TM 6113.

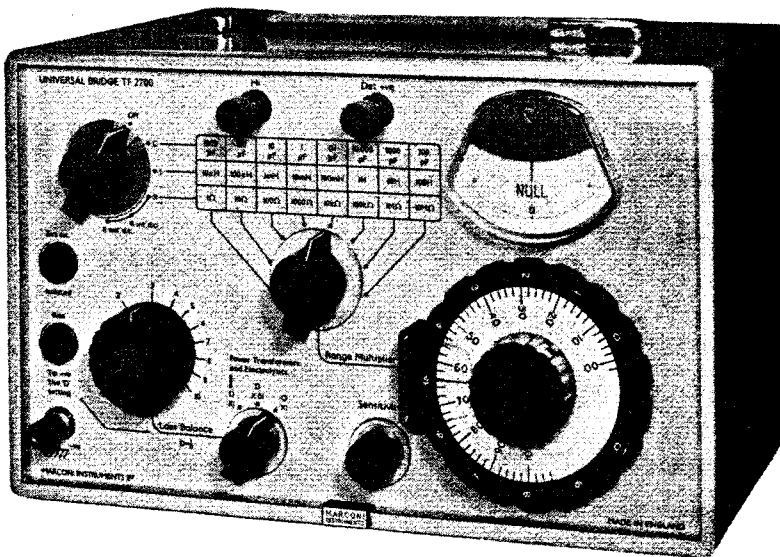

## 1.2 DATA SUMMARY

### RANGES

Capacitance:	0.5 pF to 1100 $\mu$ F in 8 ranges of 110 pF to 1100 $\mu$ F full scale.
Inductance:	0.2 $\mu$ H to 110 H in 8 ranges of 11 $\mu$ H to 110 H full scale.
Resistance:	10 m $\Omega$ to 11 M $\Omega$ in 8 ranges of 1.1 $\Omega$ to 11 M $\Omega$ full scale.
Q Indication:	0 to 10 at 1 kc/s.
D Indication:	0 to 0.1 or 0 to 10 at 1 kc/s.

### ACCURACY

Basic Accuracy:	$\pm 1\%$ of reading $\pm 0.1\%$ of range full scale.
Inductance:	Additional $-0.2\%$ of reading, $+0 -0.3 \mu$ H.
<u>First Ranges only:</u>	
Capacitance, 100 $\mu$ F to 1100 $\mu$ F:	$\pm 2\%$ of reading, $\pm 1 \mu$ F.
Inductance, 0.2 $\mu$ H to 11 $\mu$ H:	$+2\% -10\%$ of reading, $+0 -0.3 \mu$ H dependent upon Q.
Resistance, 10 m $\Omega$ to 1.1 $\Omega$ :	$\pm 2\%$ of reading, $\pm 1 \text{ m}\Omega$ .
Residuals to be subtracted:	C <sub>0</sub> , approx. 0.2 pF. L <sub>0</sub> , approx. 0.2 $\mu$ H. R <sub>0</sub> , approx. 2 m $\Omega$ .

### BRIDGE SOURCE

Internal:	1 kc/s $\pm 5\%$ oscillator for a.c. measurements of C, L, and R. 9 V battery for d.c. measurements of R between 1.2 $\Omega$ and 50 k $\Omega$ .
-----------	---

**External:**

A. F. from 20 c/s to 20 kc/s may be used for C, L, and R measurements where an alternative frequency is more appropriate. Additional bridge error is normally less than 0.25%.

D. C. may be used for R measurements in place of internal battery to improve the d. c. sensitivity at range extremes. (For low d. c. R values a sensitive galvanometer is also required.)

**FACILITIES:**

A polarizing voltage may be applied to the component under test. Non-linear elements may be tested by applying a variable d. c. bias or a. f. signal.

**POWER SUPPLY:**

Internal 9 V battery, world standard type; usual current drain approx. 7 mA.

**DIMENSIONS & WEIGHT:**

Height	Width	Depth	Weight
8 in	11½ in	8 in	8½ lb
(23.5 cm)	(29 cm)	(23.5 cm)	(3.8 kg)

### 1.3 OPTIONAL ACCESSORIES

#### D.C. Choke Adaptor, Type TM 6113

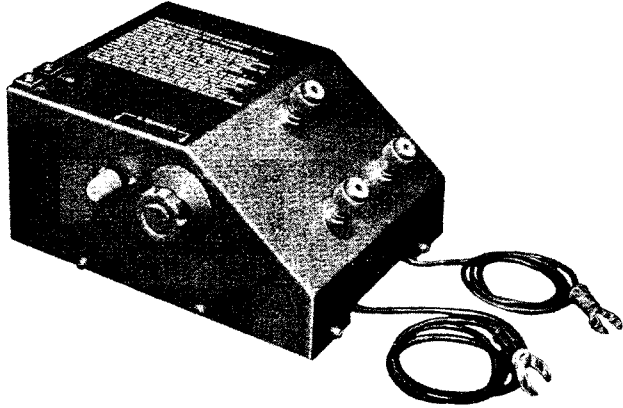

This enables d.c. currents up to 200 mA from an external supply to be passed through inductors under test at 1 kc/s in the range 100 mH to 100 H. It is fitted with spade-ended leads for connecting to the bridge terminals. Errors introduced by the Adaptor do not generally exceed 3% and may be eliminated by simple substitution methods.

#### Isolating Transformer, Type TM 7120

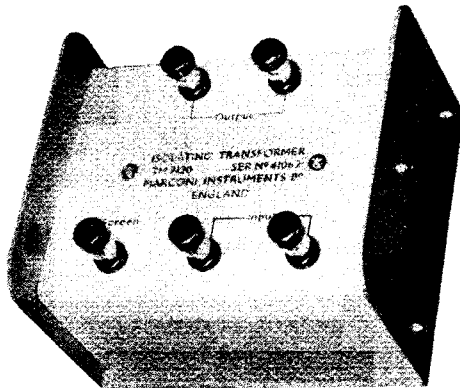

This is intended for connection between the bridge and an external a.f. energizing source in order to keep the bridge isolated from earth.

## 2 OPERATION

### 2.1 GENERAL

The operational controls of this bridge are arranged to provide an easy to use, direct reading measurement system. Fig. 2.3 summarizes the control functions. (See page 10.)

#### 2.1.1 BALANCING THE BRIDGE

Normal balancing procedure entails adjusting the main BALANCE controls, in conjunction with the LOSS BALANCE control for reactive components, in order to bring the meter to as near zero deflection as possible. The SENSITIVITY control allows the detector sensitivity to be reduced for a clearer meter indication of approaching balance with components of unknown value.

The meter deflection will always be to the right of zero for a.c. measurements; but for d.c. resistance measurements it will swing through zero as the balance point is passed so that when the deflection is to the left of zero the value of the unknown is higher than the setting of the bridge and vice versa.

Failure to obtain a complete balance null during a.c. measurements may be for one or more of the following reasons:

- |            |   |
|------------|---|
| R          | Too much stray capacitance or inductance.   |
| C and L    | Incorrect adjustment of the LOSS BALANCE particularly at low Q or high D settings. This may be due to the limited resolution of the control at Q less than 1. Alternatively it may mean that the loss of the test component is too complex to be simply resolved by either series or parallel loss balance. This could mean that it is frequency conscious so that the balance point for the harmonic content of the a.f. source is different from that of the fundamental. Any external a.f. signal used to energize the bridge should therefore be free from harmonics and mains hum; it may be necessary to use an external frequency selective detector, connected between the DET +VE and -VE (chassis) terminals. |
| C, L and R | Pick up of interference, e.g., mains hum, by the test component or its connections, see Section 2.3. Check for pick up by inserting an open circuit jack plug in the EXT A.C. socket when the meter indication should fall to zero.   |

### 2.1.2 READING THE RESULT

The main BALANCE controls of the bridge comprise a ten position switch with a variable interpolating control mounted concentrically. The switch provides increments of 0.1 between each position. The variable control covers one increment, with slight overlap; its calibration of 00 to 100 giving the second decimal place with intermediate divisions of 0.002. The overall calibration is therefore 0 to over 1.1; examples of BALANCE control readings are given in Fig. 2.1.

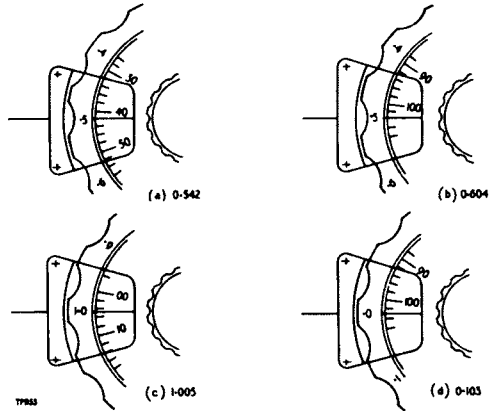

Fig. 2.1 Balance Control Indication

The table of range full scale values is linked to the BALANCE controls by the RANGE MULTIPLIER switch. The correct impedance value is obtained by multiplying the BALANCE control reading by the full scale value indicated by the FUNCTION and RANGE MULTIPLIER switches. Fig. 2.2 shows the bridge set to a value of 66.6 mH.

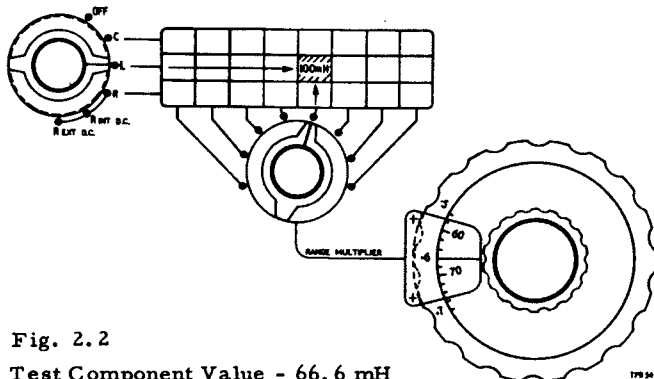

Fig. 2.2

Test Component Value - 66.6 mH



## 2.2 BATTERY CHECK

Since the bridge is battery powered its measurement sensitivity will be dependent on battery voltage. This may be monitored by connecting a voltmeter or an ammeter between the DET +VE and -VE (chassis) terminals with the bridge set to the 10 M $\Omega$ , R INT D.C. range. The voltage measured should be at least 6 V or the current at least 40 mA; if not, the battery should be replaced, for details see Section 4.1.

**NOTE:** In order to preserve the battery the instrument should be switched OFF after each measurement. When an external bias is being used the precautions given in the appropriate Operation section must be observed before altering the positions of the FUNCTION and RANGE MULTIPLIER switches.

## 2.3 CONNECTIONS

Components to be measured are connected across the two large terminals marked HI and DET +VE. The connecting leads should be kept as short as possible in order to avoid introducing stray capacitance and mains hum pick up which will obscure the balance indication.

When measuring large items or components it is important to avoid the introduction of external interference signals via the DET +VE terminal or else a poor or false balance will be obtained. If the component has an isolated screen it is probably best to connect this to the -VE (chassis) terminal; but in the event of this screen having too large a capacity (say over 200 pF) to the contents on test, it may be alternatively connected to the HI terminal. The screen in this case must be well isolated or spaced from the bridge case to avoid re-introducing the stray capacity.

Two P40 jack plugs are provided with the Bridge for the connection of external a.c. and d.c. supplies. An alternative a.f. energizing source should normally be connected to a jack plug inserted into the EXT A.C. socket. The d.c. supply for a polarizing bias should be similarly connected to the BIAS socket.

For some measurements an alternative detector may be connected between the DET +VE and -VE (chassis) terminals in order to obtain a more sensitive balance indication. Full details of these connections are given in the section appropriate to the desired type of measurement.

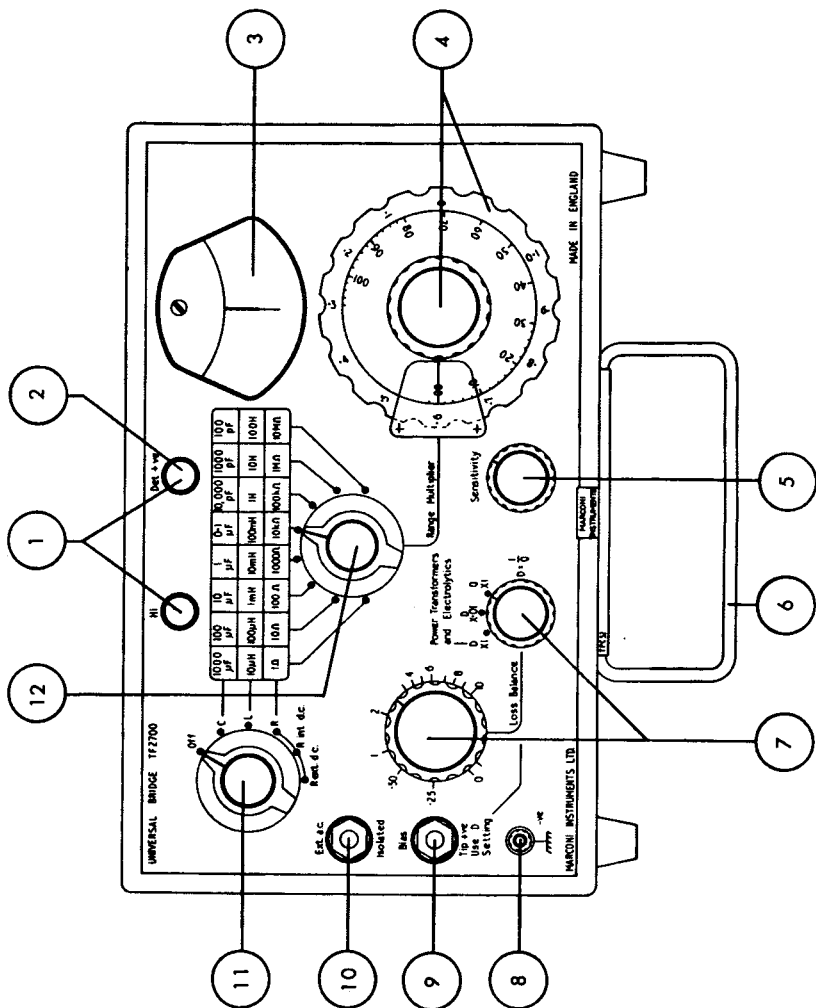

Fig. 2.3 Controls and Operational Facilities

### KEY FOR FIG. 2.3 CONTROLS AND OPERATIONAL FACILITIES

- 1 **TEST TERMINALS.** Connect the test component to these, keeping leads short, with earthy screening to HI. Keep large components well clear of case.
- 2 **DET +VE TERMINAL.** Connect external detector, or d.c. supply for better resistance discrimination.
- 3 **METER.** With a.c. measurements, pointer swings right of zero only; with d.c., pointer swings through zero at balance. Check zero before making d.c. measurements.
- 4 **BALANCE CONTROLS.** Adjust in conjunction with **LOSS BALANCE** to bring meter to zero. Inner control covers one step of outer switch.
- 5 **SENSITIVITY.** Adjust to give initial meter deflection of less than full scale. Turn fully clockwise for maximum detector sensitivity at balance null.
- 6 **SUPPORT.** Hinges downward to raise front of instrument.
- 7 **LOSS BALANCE CONTROLS.** Adjust in conjunction with **BALANCE** control. Setting of D-Q switch depends on predominant loss of test component.
- 8 **-VE (chassis) TERMINAL.** Connect to earthy or negative side of external supply as directed.
- 9 **BIAS SOCKET.** External d.c. supply of up to 500 V and 40 mA may be applied conditionally for polarizing test component.
- 10 **EXT A.C. SOCKET.** External energizing source from 20 c/s to 20 kc/s may be used; inserting jack plug switches off internal oscillator.
- 11 **FUNCTION SWITCH.** Select type of impedance measurement; C, L, or R, a.c. or d.c. Disconnect external supplies before altering switch setting.
- 12 **RANGE MULTIPLIER.** Multiply **BALANCE** control setting by full scale value indicated by switch.

## 2.4 CAPACITANCE MEASUREMENTS

Capacitance values of 0.5 pF to 1100  $\mu$ F may be measured at 1 kc/s from the internal oscillator or at frequencies of 20 c/s to 20 kc/s from an external source where an alternative frequency is more appropriate. Fig. 2.4 shows the basic bridge configuration used for these measurements. In addition to an external a. c. source, an external d. c. supply may also be connected for the polarization of electrolytic capacitors.

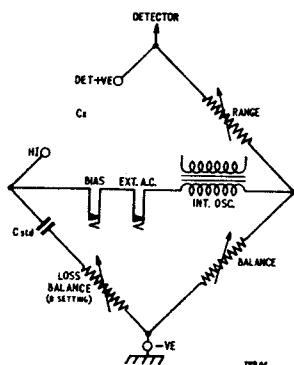

Fig. 2.4  
Basic Capacitance Bridge

### 2.4.1 MEASUREMENTS USING THE INTERNAL 1 kc/s SOURCE

- (1) Connect the component to the test terminals.
- (2) Select the range full scale, appropriate to the expected value of capacitance, with the FUNCTION and RANGE MULTIPLIER switches.
- (3) Set the D-Q switch to D x .01 for normal capacitors and to D x 1 for electrolytics.
- (4) Set the LOSS BALANCE control to about 1, and set the SENSITIVITY control to give a meter deflection of less than full scale.
- (5) Balance the bridge with the main BALANCE and LOSS BALANCE controls, increasing the sensitivity to keep the meter deflection above zero until the SENSITIVITY control is fully clockwise.

The capacitance of the component under test is given by multiplying the setting of the main BALANCE control with the range full scale, as described in Section 2.1; with values below 10 pF it is advisable to check the  $C_0$  of the bridge by balancing it with the test terminals open circuited. Since the calibration of the LOSS BALANCE control is only nominal its setting for balance must only be taken as a guide to the quality of the test component; see Section 2.8 for further details.

### 2.4.2 MEASUREMENTS USING AN EXTERNAL A. F. SOURCE

An alternative frequency may sometimes be used to advantage for high value capacitors, especially electrolytics as these are often manufactured to have a specific 50 to 120 c/s value. Also at lower frequencies the effect of lead inductance is much less significant, and the LOSS BALANCE control setting becomes proportionately less critical.

The measurement procedure is similar to that described in Section 2.4.1 and details of connections are given in Section 2.7. When using frequencies other than 1 kc/s multiply the D and Q scales by a factor of  $f/1000$ , where  $f$  is the frequency in c/s.

### 2.4.3 ELECTROLYTIC CAPACITORS AND USE OF POLARIZING BIAS

Due to their construction electrolytic capacitors often have relatively large series and parallel loss components. The series loss is usually greater and so the D setting of the LOSS BALANCE controls should be used, this being essential when a polarizing voltage is applied.

The LOSS BALANCE adjustment may be found to be rather critical therefore the sensitivity should be reduced in order to obtain a more satisfactory balance. Too high an accuracy has little meaning for very high loss components and no more sensitivity is desirable than is justified by the component quality.

#### Application of Polarizing D. C. Bias

Polarization of normal quality electrolytic capacitors does not have any great effect upon the capacitance value unless applied for a considerable time. A polarizing d. c. supply may be applied to the capacitor under test, however, via the BIAS socket, as shown in Fig. 2.5.

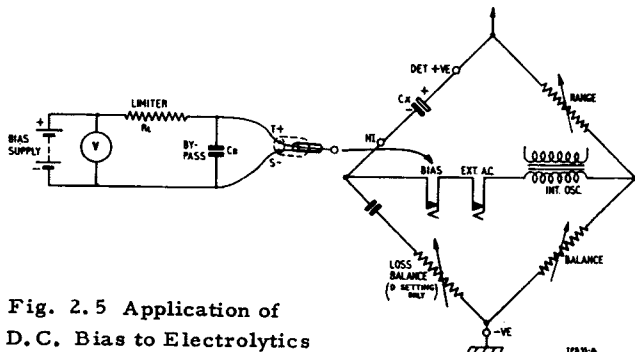

Fig. 2.5 Application of D. C. Bias to Electrolytics

A suitably limited voltage of up to 500 V d. c. should be connected to the BIAS jack plug, tip positive, sleeve negative. Since this bias is fed to  $C_X$  via the RANGE resistor, a limiting resistor  $R_L$ , must be added in series with the supply to prevent the  $\frac{1}{2}$  W rating of the RANGE resistor from being exceeded in the event of  $C_X$  becoming short circuited. Recommended values for  $R_L$  are :-

- (a) 5 k $\Omega$  per 100 V when  $C_X$  is greater than 1  $\mu$ F.
- (b) 25 k $\Omega$  per 100 V when  $C_X$  is less than 1  $\mu$ F.

The by-pass capacitor,  $C_B$ , is necessary in order to ensure an a. c. path for the bridge energizing signal. It should be at least the full scale value of the range in use or 1  $\mu$ F, whichever is the larger, and of appropriate voltage rating.

The stray capacitance between the bias supply and bridge must be kept to a minimum, preferably less than 100 pF. If the supply is earthed, it is probably only necessary to keep the bridge about 6 in (15 cm) from the nearest earthed metalwork, and to avoid handling the case whilst balancing the bridge.

When an external a. c. source is also being used it will be internally connected to the positive side of the bias supply. If, however, measurements of an earthed capacitance are to be made it may be more convenient if the two jack plugs are inter-changed.

#### WARNING :

- (1) The bridge case is connected to the positive side of the bias supply via the BALANCE resistors (0 to 1100  $\Omega$ ), and the EXT A. C. socket. Note also that the negative side of the supply is connected to the HI terminal.
- (2) The bias supply must be switched OFF before changing the bridge configuration or switching the bridge off.

#### 2.4.4 MEASUREMENT OF CAPACITANCE TO TRUE EARTH

This measurement may be carried out provided the HI terminal is connected to the earthed terminal of the capacitor under test. Fig. 2.6 shows the connections. If the test capacitor is some distance from the bridge a screened lead should be used with the screen connected to true earth. The capacitance of the lead must then be subtracted from the results.

It is important to minimize the stray capacitance of the bridge case to earth for this measurement. Keep the bridge at least 6 in (15 cm) from earthed metalwork and avoid handling the case while balancing it.

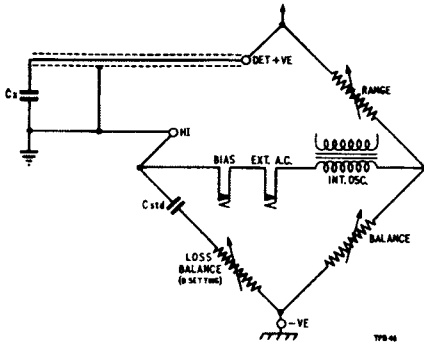

Fig. 2.6 Measurement of Capacitance to True Earth

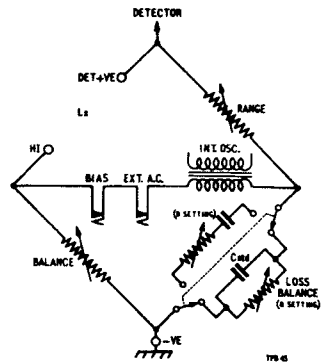

Fig. 2.7 Basic Inductance Bridge

## 2.5 INDUCTANCE MEASUREMENTS

Inductance values of  $0.2 \mu\text{H}$  to  $110\text{H}$  may be measured at  $1 \text{ kc/s}$  from the internal oscillator or at frequencies of  $20 \text{ c/s}$  to  $20 \text{ kc/s}$ , as appropriate to the inductor, from an external source. Fig. 2.7 shows the basic bridge configuration used for these measurements. The application of an external d.c. bias also enables measurements such as incremental inductance of d.c. polarized smoothing chokes to be made.

### 2.5.1 MEASUREMENTS USING THE INTERNAL $1 \text{ kc/s}$ SOURCE

- (1) Connect the component to the test terminals.
- (2) Select the range full scale, appropriate to the expected value of inductance, with the FUNCTION and RANGE MULTIPLIER switches.
- (3) Set the D-Q switch to :-
  - (i) Q for air cored coils,
  - (ii) D x .01 for high Q filter coils,
  - (iii) D x 1 for laminated iron cored inductors.
- (4) Set the LOSS BALANCE control to about 1, and set the SENSITIVITY control to give a meter deflection of less than full scale.
- (5) Balance the bridge with the main BALANCE and LOSS BALANCE controls, increasing the sensitivity to keep the meter deflection above zero until the SENSITIVITY control is as fully clockwise as possible for the most discriminating balance.

Note : The LOSS BALANCE setting is very critical for a Q less than 2 or a D greater than 0.5 and it is necessary to persevere until the settings which give the lowest meter deflection are obtained. This is especially important at low Q due to interaction of the controls. Alternative settings should be tried.

The inductance value of the component under test is given by multiplying the setting of the main BALANCE control with the range full scale, as described in Section 2.1. Since the calibration of the LOSS BALANCE control is only nominal its setting for balance must only be taken as a guide to the test component's quality; see Section 2.8 for further details.

Air cored coils should be spaced clear of metalwork by one or two diameters to avoid alteration of the inductance by induced currents.

Self capacitance of high value inductors can affect the measured inductance value, though this is more noticeable at higher frequencies. The connecting leads should therefore be kept spaced apart.

 With magnetic cored inductors it may be necessary to position them so that pick up of external magnetic fields is low enough not to affect the balance indication. The amount of pick up may be checked by inserting an open circuited jack plug into the EXT A.C. socket; this will switch off the oscillator, so that only pick up will be detected. The residual meter indication should be very low. Magnetic cores also have non-linear characteristics so that a true balance is difficult to obtain. Use only sufficient sensitivity for the accuracy required, and consider the use of d.c. bias or an alternative frequency.

## 2.5.2 MEASUREMENTS USING AN EXTERNAL A. F. SOURCE

It may be more desirable to measure the inductance of some components at frequencies other than 1 kc/s. Measurements on smoothing chokes at mains frequency, or on components of ultrasonic equipment at 20 kc/s can provide more realistic results.

The measurement procedure is similar to that described in Section 2.5.1, and details of connections are given in Section 2.7. When using frequencies other than 1 kc/s multiply the D and Q scales by a factor of  $f/1000$ , where  $f$  is the frequency in c/s.

## 2.5.3 INCREMENTAL INDUCTANCE AND USE OF POLARIZING BIAS

Due to the non-linear B/H relationship of iron cored inductors it is often required to know the incremental inductance of a component. This is the inductance value measured with a small a.c. signal, while a d.c. bias



is passed through the component to take the operating point to the desired position on the B/H curve.

Measurements of this type may be carried out with this bridge using several alternative methods:-

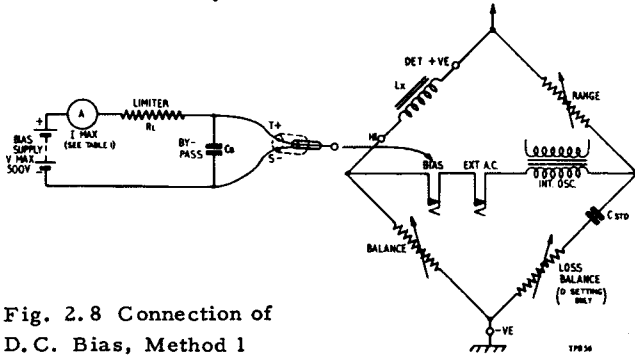

Fig. 2.8 Connection of D.C. Bias, Method 1

- (1) The external d.c. bias may be applied via the BIAS socket as shown in Fig. 2.8. A suitably limited voltage of up to 500 V d.c. should be connected to the BIAS jack plug, tip positive, sleeve negative. Since the bias current also flows through the range resistor, the oscillator transformer and the external a.c. supply, if being used, the permissible current is limited by the  $\frac{1}{2}$  W rating of the range resistors. TABLE 1 lists the maximum current for any range.

The by-pass capacitor  $C_p$  should be of a suitable value to pass the a.c. signal and of appropriate voltage rating.

TABLE 1

Range full scale	100 H	10 H	1 H	100 mH
Range Resistor	1 M $\Omega$	100 k $\Omega$	10 k $\Omega$	1 k $\Omega$
$I_{max}$	0.5 mA	2.2 mA	7 mA	22 mA
Range full scale	10 mH	1 mH	100 $\mu$ H	10 $\mu$ H
Range Resistor	100 $\Omega$	10 $\Omega$	1 $\Omega$	0.1 $\Omega$
$I_{max}$	70 mA	200 mA	200 mA	200 mA

Excessive capacitance between the bias supply and the bridge case should be avoided, as it may affect the LOSS BALANCE setting. Isolation of one or the other from true earth is advisable.

CAUTION : To avoid high transient voltages short circuit  $L_x$  before switching off the bias supply.

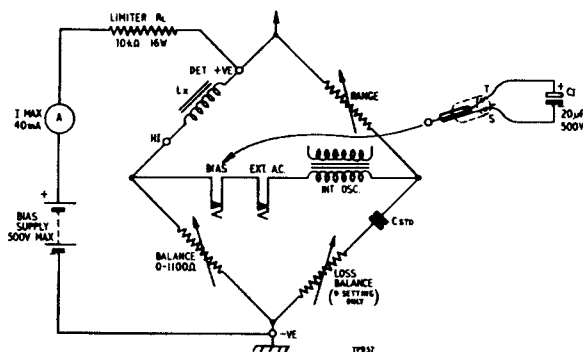

Fig. 2.9 Connection to D.C. Bias, Method 2

- (2) The method shown in Fig. 2.9 allows up to 40 mA to be passed through the test component on any range.

The inclusion of an isolating capacitor,  $C_1$ , in series with the a.c. source ensures that all the bias current flows through the test component. The bias current also flows through the 'BALANCE' resistors so that alteration of their value during balancing will vary the current. A large value limiting resistor,  $R_L$ , included in series with the supply will keep these variations to a minimum; it should be mounted close to the DET +VE terminal to avoid interference pick up. The wattage rating of the BALANCE resistors limits the maximum permissible bias current on any range to 40 mA.

Since the detector is not frequency selective it is very important to keep the stray frequencies introduced to the bridge to an absolute minimum, so that the balance indication is not obscured. The bias supply, therefore, should be hum free; the bridge and the leads, connected to it positioned to minimize pick up. The hum level may be checked by inserting an open circuited jack plug into the EXT A.C. socket; the meter indication should be very low.

CAUTION : To avoid high transient voltages short circuit  $L_x$  before switching off the bias supply.

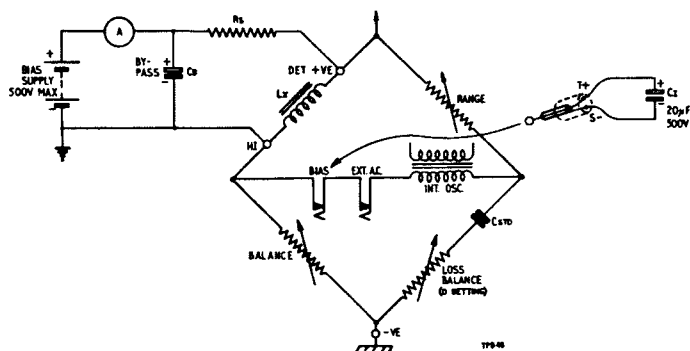

Fig. 2.10 Connection of D.C. Bias, Method 3

- (3) The method shown in Fig. 2.10 allows any required current to be passed through the component under test,  $L_x$ , limited only by  $R_s$ . Because the bias supply is connected directly across  $L_x$  its source resistance will appear as an increased shunt loss. The series resistor,  $R_s$ , must therefore, be included to keep the shunt loss within the range covered by the LOSS BALANCE control, otherwise it may not be possible to balance the bridge. The value of  $R_s$  should be at least  $1000 \Omega$  per 1 H of test component value.

Isolating capacitor,  $C_1$ , connected to a jack plug in the BIAS socket prevents the bias current flowing through any other of the bridge arms. The bias supply, of 500 V maximum, should be hum free and a capacitor,  $C_p$ , should be included to by-pass any pick up. Check for excessive hum and noise pick up, by inserting an open circuit jack plug into the EXT A.C. socket, the meter indication at the sensitivity in use should be negligibly small.

**CAUTION:** To avoid high transient voltages short circuit  $L_x$  before switching off the bias supply.

- (4) This method, shown in Fig. 2.11, uses the D.C. Choke Adaptor, TM 6113, available as an optional accessory. This Adaptor is designed for use at 1 kc/s only and enables currents up to 200 mA d.c. to be passed through inductors in the range 100 mH to 100 H. It employs two tuned circuits to isolate the bridge from the d.c. source. These provide a high impedance to the a.c. signal and are capable of carrying the bias current without change to their tuning.

Full operational procedure is given in the separate handbook supplied with the adaptor. See also the note at the end of section 3.3.

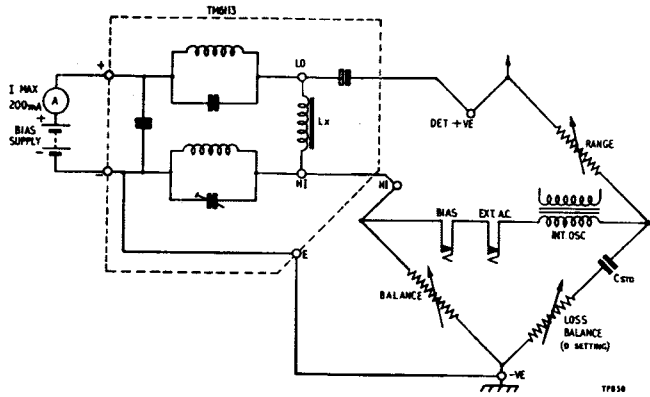
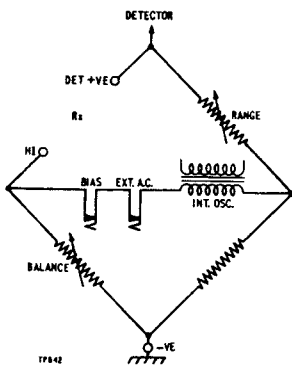

Fig. 2.11 Use of D. C. Choke Adaptor

## 2.6 RESISTANCE MEASUREMENTS

Resistance may be measured at 1 kc/s from the internal oscillator, at frequencies of 20 c/s to 20 kc/s from an external source, or at d.c. from the internal battery or an external d. c. supply. Fig. 2.12 shows the basic bridge configuration for measurements with (a) a.c. and (b) d.c. For resistance measurements the LOSS BALANCE arm is replaced by a  $100\ \Omega$  resistor, and for d.c. measurements the meter only is used as the detector.

**R**



(a) A.C.

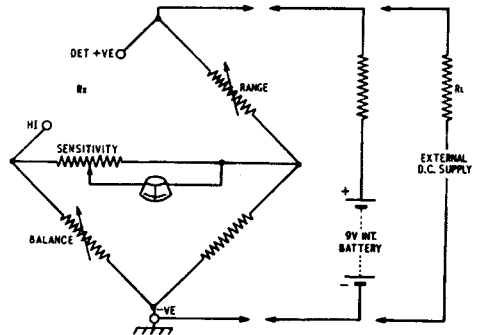

(b) D.C.

Fig. 2.12 Basic Resistance Bridges

$C_V \cdot R_B$  must equal  $C_S \cdot R_X$ , where  $R_B$  is the value of BALANCE arm resistance required for  $R_X$ . For example, when  $R_X = 10 \text{ M}\Omega$ ,  $C_S = 1 \text{ pF}$ , and  $R_B = 1000 \Omega$ , then  $C_V$  should be 10,000 pF.

If the test component,  $R_X$ , has excessive series inductance,  $L_S$ , a variable capacitor  $C_V$ , connected between the tip of the EXT A. C. jack plug and the -VE (chassis) terminal may be used to cancel out  $L_S$ . The value of  $C_V$  may be determined from the relationship:

$$C_V = \frac{L_S}{100 R_X}$$

### Incremental Resistance

Measurements on non-linear resistive components, such as thermistors, sensitive heaters, diodes, etc., may be made by using a d. c. bias. The basic measurement is made with a. c. from the internal 1 kc/s oscillator or an external source. The d. c. is applied via a jack plug inserted into the BIAS socket; tip positive, sleeve negative. A limiting resistor should be included in series with the bias supply, its value being dependent on the voltage used, as shown in Table 2. A by-pass capacitor of at least  $1 \mu\text{F}$  should also be included across the jack plug connections to provide a path for the a. c. signal. The bias current is adjusted to bring the test component to the desired working point; if necessary reduce the amplitude of the a. c. until a good balance is obtained.

TABLE 2

Bias Supply	Max 40 V	35 V	30 V	25 V	20 V	15 V	10 V	5 V	2 V
Limiter	1 k $\Omega$	750 $\Omega$	500 $\Omega$	300 $\Omega$	200 $\Omega$	120 $\Omega$	40 $\Omega$	22 $\Omega$	10 $\Omega$

Note: Output from the internal oscillator is limited to about 170 mV or 70 mA on ranges up to 100 k $\Omega$  full scale, and to 1.5 V on the 1 and 10 M $\Omega$  ranges.

R

### 2.6.3 MEASUREMENTS USING THE INTERNAL BATTERY

The internal d. c. source is limited to 9 V and 60 mA. This gives sufficient discrimination to measure resistance values between 1.2  $\Omega$  and 50 k $\Omega$ . Increased sensitivity for values outside this range may be obtained by using the internal 1 kc/s source, or external a. c. or d. c. supplies.

- (1) Connect the component to the test terminals and check the mechanical zero of the meter with the bridge switched OFF.
- (2) Select the range full scale, appropriate to the expected value of resistance, with the RANGE MULTIPLIER switch. Set the FUNCTION switch to R INT D. C.
- (3) Set the SENSITIVITY control to give a meter deflection of less than full scale. If the deflection is left of zero the value of the unknown is higher than the setting of the bridge and vice versa.
- (4) Balance the bridge with the main BALANCE control, increasing the sensitivity as necessary to give a final balance with the meter at zero and the SENSITIVITY control fully clockwise.

The resistance value of the component under test is given by multiplying the setting of the BALANCE control with the range full scale, as described in Section 2.1.

#### 2.6.4 MEASUREMENTS USING AN EXTERNAL D. C. SOURCE

By using an external d. c. source of higher voltage than the 9 V internal battery greater discrimination may be obtained on ranges of 10 k $\Omega$  full scale and above. No advantage will be gained, however, by using an external d. c. source on the lower ranges, except for very low values as described later.

##### High Resistance

Fig. 2.13 shows the method of applying the external d. c. voltage for high resistance measurements. The positive side of the supply should be

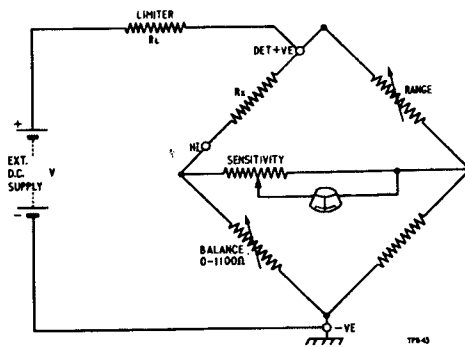

Fig. 2.13 High Value Resistance Measurement with External D. C. Source



connected to the DET +VE terminal and the negative to the -VE (chassis) terminal. Limiting resistor  $R_L$  must be included to protect the bridge resistors from excessive currents. Table 3 gives the minimum value of limiting resistor and maximum permissible value of voltage for any range.

TABLE 3

Range	10 k $\Omega$	100 k $\Omega$	1 M $\Omega$	10 M $\Omega$
$V_{max}$	22 V	70 V	220 V	500 V
$R_L \text{ min}$	360 $\Omega$	2.2 k $\Omega$	25 k $\Omega$	50 k $\Omega$

Measurement procedure is similar to that described in Section 2.6.3. Care should be taken when using high voltages; always switch off the external supply before altering the position of the FUNCTION switch.

### Low Resistance

Discrimination on the two lowest ranges may be improved by using the method shown in Fig. 2.14. Set the FUNCTION switch to R~ and connect a 4.5 V battery to a jack plug inserted into the EXT A.C. socket. A 22  $\Omega$  limiting resistor must be included in series with the battery to protect the bridge resistors. A sensitive galvanometer, connected between the DET +VE and -VE (chassis) terminals, replaces the internal meter which only has a 150-0-150  $\mu$ A movement. The residual resistance of the bridge,  $R_0$ , may be checked by balancing the bridge with the test terminals short circuited.

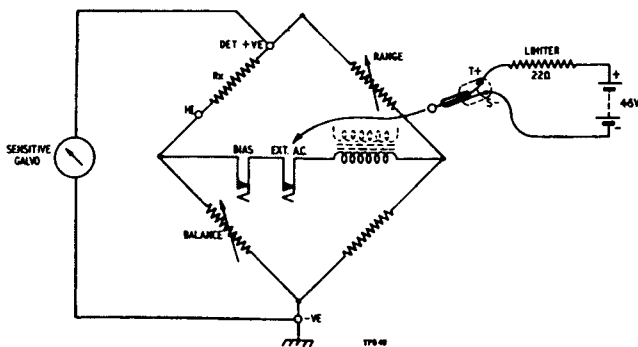

Fig. 2.14 Low Value Resistance Measurement with External D. C. Source

## 27 CONNECTION OF EXTERNAL A.C. SOURCE

The bridge may be energized from an external a.c. supply at frequencies between 20 c/s and 20 kc/s. The external source is connected to the bridge via a jack plug inserted into the EXT A.C. socket; the action of inserting the plug switches off the internal oscillator.

Ideally the a.f. supply should be connected via an isolating transformer, such as Marconitype TM 7120 which is available as an optional accessory. The use of a transformer designed specifically for the purpose eliminates the possibility of a false balance due to capacitive coupling when measuring low impedances at high frequencies. The arrangement of connections with transformer TM 7120 is shown in Fig. 2.15. The earthy side of the A.F. Oscillator output should be connected to the INPUT terminal on TM 7120 adjacent to the SCREEN terminal. These two terminals should then be linked to the -VE (chassis) terminal of the bridge.

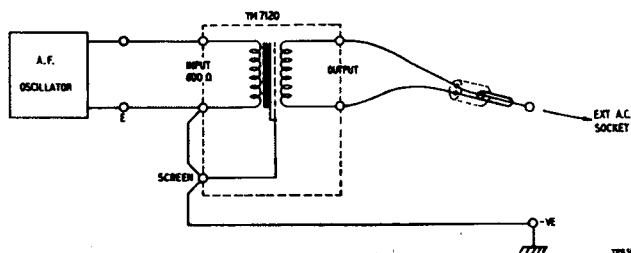

Fig. 2.15 Connection of External A. F. Source via Isolating Transformer

The TM 7120 transformer has been designed to match an oscillator output impedance of  $600\ \Omega$  but may be used for other impedances provided that for lower impedances the input power is limited to  $\frac{1}{2}W$ . The load on the secondary will vary from  $2.5\ \Omega$  on the lowest range of the bridge to about  $1\ k\Omega$  on the highest depending upon the function selected and the BALANCE and LOSS BALANCE settings.

If a TM 7120 isolating transformer is not available, the next best alternative is to use a battery powered audio oscillator isolated from true earth. The case or earthy output of such an oscillator should be connected to the sleeve of the jack plug, and the oscillator spaced about 10 in (25 cm) from the bridge. If only an a.c. mains power oscillator is available then proceed as detailed above, place the bridge clear of any earthed metalwork, avoid handling its case while making the measurement and guard against hum pick up from the test component.



For low frequency measurements, such as 50 c/s, an ordinary mains transformer may be used to supply the bridge, but it is best to have the secondary screened from the primary and for the winding capacity to be less than 100 pF. Connect the screen to the -VE (chassis) terminal.

When using a high voltage level, overload of the first detector stage may obscure initial balance indication. The sensitivity of the detector may be controlled under these circumstances by means of a variable resistor of, say, 10 k $\Omega$  connected between the DET +VE and -VE (chassis) terminals. If external bias is also being applied, block the d.c. by connecting a capacitor of about 4  $\mu$ F in series with the variable resistor.

### Maximum A. C. Voltage

The maximum permissible voltage that may be applied to the bridge is governed by the current rating of the bridge resistors. It is very much dependent upon the range in use and whether the test component is C, L, or R. A safe maximum e.m.f. for all ranges is 35 V r.m.s. open circuit from a 600  $\Omega$  source. This limits the maximum power into the bridge and test component to  $\frac{1}{2}$ W. This voltage is more than adequate for all normal measurements, the e.m.f. from the internal oscillator being 170 mV on the six lowest impedance ranges and 1.5 V on the top two.

### A. C. Voltage across Inductors

With the maximum voltage limitations given in the previous paragraph it is possible to have 3 to 4 V at 1 kc/s across an inductor on test on the top three ranges (values from 1 to 110 H). With lower value inductors and lower frequencies the permissible inductor voltage is proportionately less. The actual voltage across the inductor on test at balance may be measured with a high impedance valve voltmeter connected between the HI and -VE (chassis) terminals.

Table 4 gives the approximate maximum voltages across a range of inductors at the  $\frac{1}{2}$ W input limit. It will be evident that the maximum permissible a.c. voltage obtainable across inductors at low frequencies is somewhat less than may sometimes be required.

TABLE 4

$L_x$	100 c/s	1 kc/s	10 kc/s
0.3 H, 3 H, 30 H	0.5 V	5 V	25 V
0.6 H, 6 H, 60 H	1 V	10 V	25 V
1 H, 10 H, 100 H	1.5 V	12 V	25 V

## 2.8 LOSS BALANCE—Q OR D

The LOSS BALANCE control enables the resistive loss of an impedance under test to be balanced out so that the true reactance of the component may be measured more accurately.

When measuring capacitors on this bridge the LOSS BALANCE controls are normally set to D, which gives the result in terms of series capacitance,  $C_s$ , and series resistance  $R_s$ . The dissipation factor,  $D = 2\pi f C_s R_s$ . When the LOSS BALANCE is set to Q the parallel values,  $C_p$  and  $R_p$ , are measured; here  $Q = 2\pi f C_p R_p$ .

$$\frac{C_s}{C_p} = \frac{1 + Q^2}{Q^2} = 1 + D^2 \quad \text{since } D = 1/Q$$

It will be seen that for values of Q greater than 10 (D less than 0.1)  $C_s = C_p$ , within 1%.

Measurements on inductors are more dependent on their core loss for LOSS BALANCE setting. Normal air cored coils are measured in terms of series inductance  $L_s$  and series resistance,  $R_s$ , with the LOSS BALANCE at the Q setting.

$$\text{Here } Q = \frac{2\pi f L_s}{R_s}$$

High Q coils, such as ferrite cored filter coils, are measured in terms of parallel values  $L_p$  and  $R_p$ , on the D x .01 range. This is equivalent to a Q range of 10 to  $\infty$ , and for values of Q greater than 10,  $L_p = L_s$ , within 1%. With laminated iron cored inductors the predominant loss, due to the core, takes the form of parallel resistance and is measured on the D x 1 range.

$$\text{Here } D = \frac{2\pi f L_p}{R_p} \quad \text{and} \quad \frac{L_p}{L_s} = 1 + D^2$$

### Q and D with External A. F.

The Q and D ranges are proportional to frequency so that at frequencies lower than 1 kc/s the Q range may be insufficient and recourse to the D x 1 range must be made with a parallel/series conversion as above if required.

The correct adjustment of the LOSS BALANCE becomes increasingly critical at high frequencies when using D and at low frequencies using Q.

### 3 CIRCUIT SUMMARY

#### 3.1 BRIDGE CIRCUITS

The bridge circuits used in the TF 2700 are basically those used in other Marconi universal impedance bridges. A Wheatstone circuit is used for resistance measurement while inductance and capacitance are measured by comparison with a standard capacitor in R-C ratio arm circuits. The a.c. measurement circuits are shown functionally in Fig. 3.1.

With reference to the Circuit Diagram at the end of the handbook, C4 is the standard capacitor which has the LOSS BALANCE potentiometers, RV4 and RV5 connected in series or in parallel with it, according to the setting of the D-Q switch. This LOSS BALANCE arm is replaced by a 100 Ω resistor, R12, for resistance measurements.

The RANGE resistors, associated with switch SB, consist of six metal film high stability type, R15 to R20, and two wirewound, R13 and R14.

The main BALANCE control comprises an eleven step switch, SC, and a continuously variable intermediate control, RV1. This system gives good readout discrimination and improved freedom from fine balance adjustments being affected by coarseness of the potentiometer track. The bal-

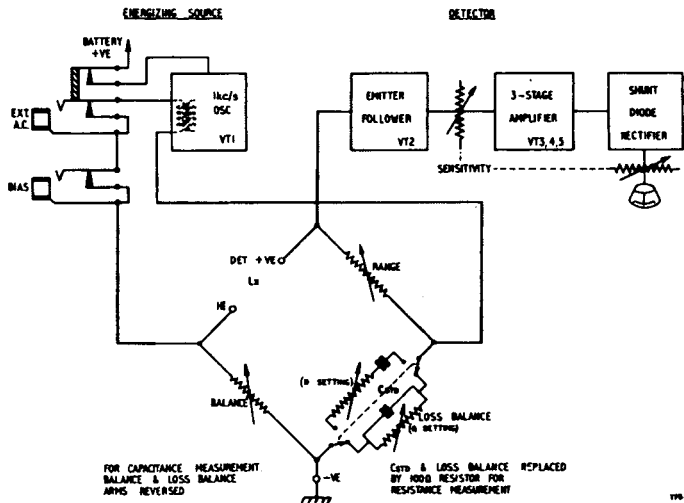

Fig. 3.1 Functional Diagram for A.C. Measurements

ance arm resistors, R7 to R10, are close tolerance wirewound type and are switched sequentially in series to give eleven values each increasing by 100  $\Omega$ . The switching sequence is 0, 100, 200, 300, 300 + 100, 300 + 200, 600, 600 + 100, 600 + 200, 600 + 300, 600 + 300 + 100.

### 3.2 BRIDGE ENERGIZING SOURCES

A single transistor, VT1, is used for the internal 1 kc/s oscillator in a tuned collector circuit. The tuned circuit comprises capacitor C1 and the primary of T1, an extension of which provides the feedback applied to the base via C2. The output is taken from the secondary of the transformer; on the six lower impedance ranges an intermediate tap is used to provide a source e.m.f. of approximately 170 mV, the two upper ranges using the full output of 1.5 V.

When a jack plug is inserted into the EXT A.C. socket the battery supply to the oscillator is disconnected and the residual charge of C3 is short circuited via R4. An external a.f. signal connected to this jack is fed to the bridge via the secondary of T1.

The internal 9 V battery is used to energize the bridge for resistance measurements at the R INT D.C. position of switch SA. A source of higher voltage may be connected between the DET +VE and -VE (chassis) terminals for better discrimination when the internal battery is disconnected at the R EXT D.C. position.

### 3.3 DETECTOR

The detector has been made unselective to enable external a.f. sources to be used for energizing the bridge, its frequency response being sensibly flat from 20 c/s to 20 kc/s. The input capacitor C5, attenuates the lower frequencies somewhat to prevent surges damaging the transistors.

An emitter follower input stage provides the high input resistance necessary to maintain sensitivity on the high impedance ranges, VT2 being a silicon transistor in order to minimize noise.

The output of the emitter follower drives a three stage amplifier via a logarithmic potentiometer. This is part of the SENSITIVITY control which consists of two ganged potentiometers; RV3 is a gain control for the amplifier and RV2 shunts the meter so that a sensitivity control is operative during d.c. resistance measurements. The amplifier comprises VT3, VT4 and VT5, all similarly biased by d.c. feedback from their collectors. The last stage has a variable emitter resistor RV6 to enable the overall sensitivity to be preset.

The amplifier output is rectified by shunt diode MR1 and fed to the meter, so that the meter always deflects to one side of zero for all a.c. measurements. Two germanium diodes MR2 and MR3 are connected across the meter as limiters to protect it from severe overloads. For d.c. resistance measurements the unbalanced output from the bridge is applied directly to the meter so that now it deflects either side of zero, passing through zero at the balance null.

**Note:**

Because the detector is unselective, pickup of stray fields in accessories such as the D. C. Choke Adaptor, TM 6113, can result in a standing reading on the meter. If this problem is not surmountable by moving the bridge and adaptor to another location, an oscilloscope or selective device can be used as an external detector so that the null can be easily found.

## **4 MAINTENANCE NOTES**

### **4.1 REPLACEMENT OF THE BATTERY**

If a battery check, as described in Section 2.2, shows that a replacement is required proceed as follows :-

- (1) Remove the formed plate fitted inside the cut-out in the rear case panel by unscrewing the two captive 2 BA screws.
- (2) Prize the two snap connectors off the battery.
- (3) Slide out the old battery and fit a new one.
- (4) Press on the snap connectors. When a similar standard 9 V battery is used, EverReady type PP9 or Exide type DT9, the connectors can only be fitted for the correct polarity. If, however, a non-standard battery has to be used the connections must have the same polarity as for the original.
- (5) Replace the plate, making sure the battery leads are not trapped.

### **4.2 REPLACEMENT OF CIRCUIT COMPONENTS**

If the precautions and limits described in Section 2 are observed the instrument should not require any maintenance other than the occasional replacement of the battery. In the event of serious damage, however, the instrument should be returned to our Service Department or nearest Area office. (For addresses, see rear cover.)

The use of high stability, close tolerance components has resulted in the almost complete absence of preset components. Should a transistor or some other component be damaged by a transient surge from an external supply or by over rating, then the subsequent replacement of the faulty component may necessitate making one or more of the re-adjustments given in this section.

#### **4.2.1 ACCESS TO INTERIOR**

The main case assembly can be removed after unscrewing the centrally located Phillips-head screws that retain the rear case panel.

#### 4.2.2 ADJUSTMENT OF DETECTOR SENSITIVITY

The detector sensitivity may be adjusted by means of variable resistor RV6, situated at the bottom of the right-hand printed board. The slider of RV6 will have been cemented with some vinyl lacquer; this must be softened with a suitable solvent, such as acetone, before attempting to reposition it.

The optimum detector sensitivity is obtained when an input of approximately  $100\ \mu\text{V}$  at  $1\ \text{kc/s}$  produces full scale deflection on the meter with the SENSITIVITY control fully clockwise. Apply the  $100\ \mu\text{V}$  signal between the DET +VE and -VE (chassis) terminals with the FUNCTION switch set to C or L. Insert an open circuit jack plug into the EXT A.C. socket to switch off the internal oscillator; also check that the internal 9 V battery does not require replacing.

#### 4.2.3 OSCILLATOR FREQUENCY

The oscillator frequency may be adjusted by padding the value of C1, which is the largest capacitor mounted between the upper tag strips on the left-hand side of the instrument.

#### 4.2.4 RANGE RESISTOR R13

R13 is a loop of resistance wire soldered between two contact tags of the RANGE MULTIPLIER switch, SB. If one end of this wire becomes detached it will be necessary to adjust its length to give the correct value when soldered back into place.

For this adjustment set the bridge to measure  $1\ \Omega$  on a.c. and connect a  $1\ \Omega \pm 0.5\%$  resistor to the test terminals. Adjust R13 for balance within 1%. The wire should be left in the form of a hairpin to minimize its inductance.

Circuit reference	Description	M.I. code	Circuit reference	Description	M.I. code
RESISTORS (contd.)			TRANSFORMER		
R28	Carb 68k $\Omega$ 10% $\frac{1}{2}$ W/55 $^{\circ}$ C	24342-131	T1	Oscillator transformer	43568-502
R29	Carb 4.7k $\Omega$ 10% $\frac{1}{2}$ W/55 $^{\circ}$ C	24342-100			
R30	Carb 2.7k $\Omega$ 10% $\frac{1}{2}$ W/55 $^{\circ}$ C	24342-092			
R31	Carb 68k $\Omega$ 10% $\frac{1}{2}$ W/55 $^{\circ}$ C	24342-131	TERMINALS		
R32	Carb 4.7k $\Omega$ 10% $\frac{1}{2}$ W/55 $^{\circ}$ C	24342-100	TP1	HI	23235-176
R33	Carb 3.3k $\Omega$ 10% $\frac{1}{2}$ W/55 $^{\circ}$ C	24342-094	TP2	DET +ve	23235-176
R34	Carb 330 $\Omega$ 10% $\frac{1}{2}$ W/55 $^{\circ}$ C	24342-063	TP3	-ve (chassis)	23235-177
VARIABLE RESISTORS			TRANSISTORS		
RV1	WW 110 $\Omega$ 5% 5W/20 $^{\circ}$ C	25824-573			
RV2	Carb 2.5k $\Omega$ 20% 2W/70 $^{\circ}$ C	25673-243	VT1	GET102	28423-876
RV3	Carb 25k $\Omega$ 20% 1W/70 $^{\circ}$ C		VT2	OC200	28433-337
RV4	WW 170 $\Omega$ 5% 4W/20 $^{\circ}$ C	25874-573	VT3	GET102	28423-876
RV5	WW 17k $\Omega$ 5% 4W/20 $^{\circ}$ C				
RV6	WW 200 $\Omega$ 10% $\frac{1}{2}$ W	25886-570			
SWITCHES			KNOBS		
SA	Function	44324-810	Function		41145-207
SB	RANGE	44325-603	RANGE		41145-206
SC	Balance	44326-207	D-Q		41145-208
SD	D-Q	44322-408	LOSS BALANCE		41142-702
			SENSITIVITY		41142-210



## CIRCUIT NOTES

### 1. COMPONENT VALUES

Resistors : No suffix = ohms. k = kilohms. M = megohms.

Capacitors : No suffix = microfarads. p = picofarads.

\* value selected during test; nominal value shown.

### 2. VOLTAGES

These are d. c. and relative to chassis unless otherwise indicated. Measured with a 20 k $\Omega$ /V meter.

### 3. SYMBOLS

 preset component

 arrow indicates clockwise rotation of knob

 panel marking

 printed board tag number

### 4. SWITCHES

Rotary switches are drawn schematically. Numbers or letters indicate control knob setting as shown in key diagrams.

1F = 1st section (front panel), front

1B = 1st section, back

2F = 2nd section, front

etc.